

INTERIOR FOLDING SYSTEMS

Section Index and General Guide

Select system for your interior folding door application.	Residential	Commercial	Industrial	Max. Door	Product	Data Sheet
APPLICATION						
Residential						
For wardrobes	■			14kg	Bifold	D20
For room dividers	■			40kg	Husky 25 & 40	D30
Commercial						
For interior residential or commercial end folding partitions	■	■		65kg	Pacer Endfold	*
For interior residential or commercial centre folding partitions	■	■		65kg	Pacer Centrefold	*
For interior residential or commercial partitions. All doors equal width	■	■		75kg	Soltaire Pivotfold 45 & 75	D40
For interior residential or commercial end folding partitions	■	■		75kg	Soltaire Endfold 45 & 75	D50
For interior residential or commercial centre folding partitions	■	■		75kg	Soltaire Centrefold 45 & 75	D60
Industrial						
For interior industrial and commercial end folding partitions			■	35kg	Council 290 Endfold	*
For interior industrial and commercial end folding partitions			■	35kg	Council 290 Pivotfold	*
For interior industrial and commercial centre folding partitions			■	35kg	Council 290 Centrefold	*
For interior industrial and commercial end folding partitions			■	70kg	Council 301 Endfold	*
For interior industrial and commercial end folding partitions			■	70kg	Council 301 Pivotfold	*
For interior industrial and commercial centre folding partitions			■	70kg	Council 301 Centrefold	*
For interior industrial and commercial end folding partitions			■	80kg	Council 305 Endfold	*
For interior industrial and commercial centre folding partitions			■	80kg	Council 305 Centrefold	*
For interior industrial and commercial folding partitions. Bottom roll.			■	70kg	College Endfold	*
For interior industrial and commercial folding partitions. Bottom roll.			■	140kg	College Endfold	*

* Please contact either your ASSA ABLOY Representative or our technical sales team for further information.

HENDERSON

BIFOLD

For folding wardrobe doors. Max 14kg.

APPLICATION

- Stable and smooth opening system for wardrobe doors that can complement any bedroom
- System allows for doors to fold back completely
- Silent and easy to fix
- Designed for timber, timber framed or composite doors
- Suitable for jambless openings

DOOR SPECIFICATION

Track System	Bifold
For Individual Doors:	
Max Door Weight	14kg
Max Door Width	530mm
Door Thickness	20-35mm
Max Door Height	2400mm

STANDARD SETS AND PACK

Sets comprise of track, top and bottom pivots, guides, hinges, all screws & fitting instructions.

Set No.	Track Length	Hardware for
HB10/2	1065mm	2 doors
HB15/4	1525mm	4 doors (2 doors to each side)
HB20/4	2135mm	4 doors (2 doors to each side)

HARDWARE SPECIFICATION

Track	H310	Aluminium (762, 1067, & 3000mm lengths)
Pivots	H311	Top pivot socket
	H312	Bottom pivot socket
	H312W	Bottom pivot socket wall fix
	H313	Top pivot
	H314	Bottom pivot
Guide	H289B	Bottom pivot set
	H315	Nylon spring loaded guide
Hinge	H282	Butt hinge
	H75X47FHSS	Stainless steel face fix hinge
	H316	Rubber buffer
	H319	Door aligner

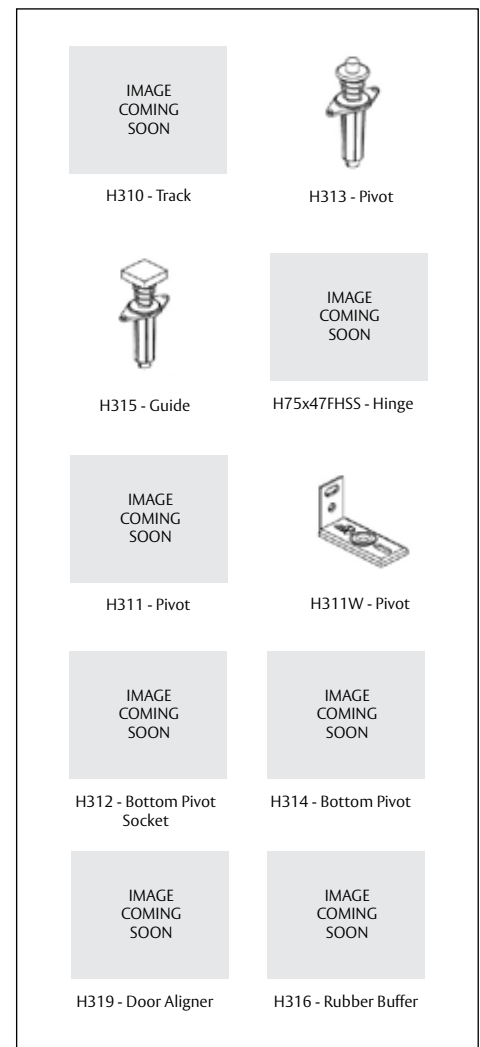



HENDERSON

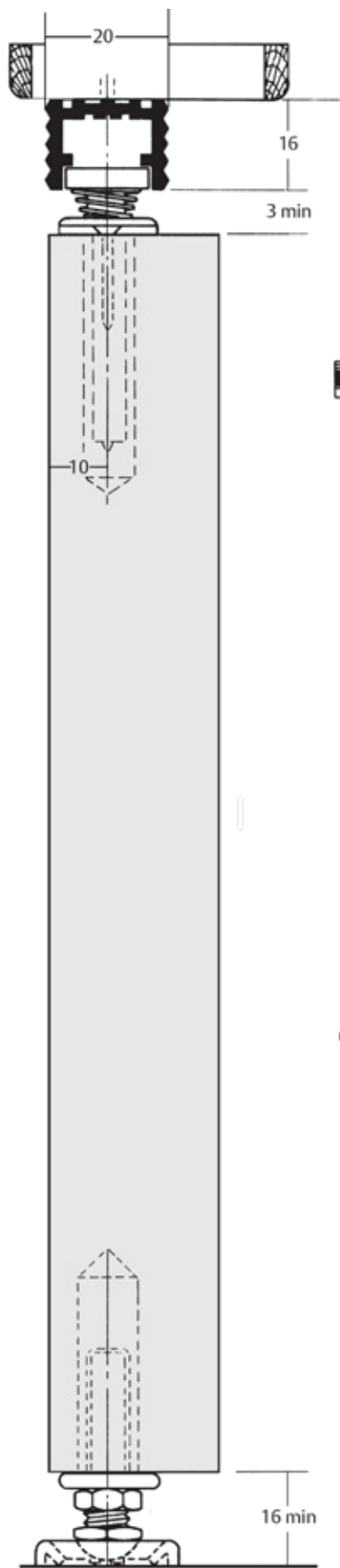

NOT TO SCALE

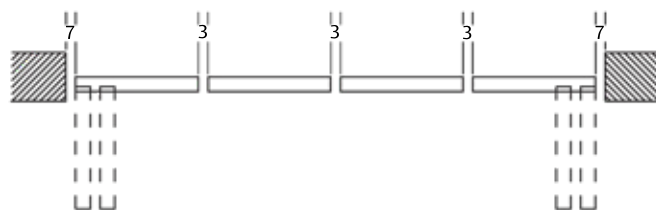
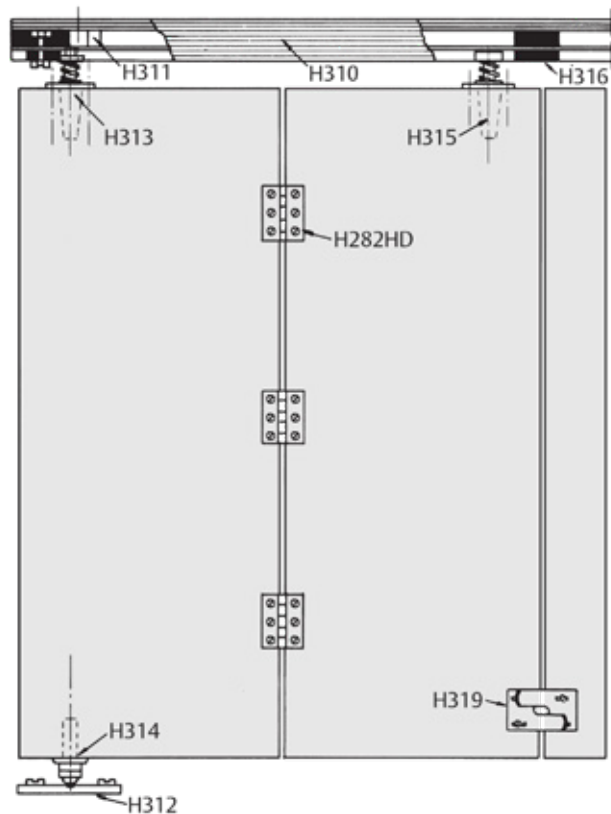

HUSKY 25 & 40

For folding doors and room dividers. Max 25kg or 40kg.

APPLICATION

- Ideally suited for light to medium weight residential folding partitions
- Concealed fixing
- Suitable for timber, timber framed and composite doors

DOOR SPECIFICATION

Track System	Husky 25	Husky 40
For Individual Doors:		
Max Door Weight	25kg	40kg
Max Door Width	600mm	750mm
Door Thickness	20-40mm	20-40mm
Max Door Height	2400mm	2400mm

STANDARD SETS AND PACK

Sets comprise of steel track, hangers, top and bottom pivots, guides (*Husky 40*), hinges, all screws & fitting instructions.

Husky 25 Set No.	Husky 40 Set No.	Track Length	Hardware for
HF25/12	-	1200mm	2 doors
HF25/24	-	2400mm	4 doors (<i>all 4 doors to one side</i>)
-	HF40/15	1500mm	2 doors
-	HF40/30	3000mm	4 doors (<i>all 4 doors to one side</i>)
Pack No.	Application		
HF2/25	Two door fittings pack 25kg.		
-	HF2/40	Two door fittings pack 40kg.	
HF4/25	Four door, one end fittings pack 25kg.		
-	HF4/40	Four door, one end fittings pack 40kg.	

HARDWARE SPECIFICATION

Track	H280	Steel (2000, 3000, 4000 & 6000mm lengths)
	H280A	Aluminium (2000, 3000, 4000 & 6000mm lengths)
	H280AN	Anodised (2000, 3000, 4000 & 6000mm lengths) Soffit fix spacing 275mm centres (<i>maximum</i>)
Pivots	H289T	Top pivot
	H289B	Bottom pivot
Hangers (2 per door)	H283N	Nylon bodied, 4-wheel adjustable hangers (<i>Husky 25</i>)
	H283	Nylon bodied, needle roller bearing hangers (<i>Husky 40</i>)
Hinge	H282HD	Husky butt hinge
	H75X47FHSS	Stainless steel flush hinge
	H90X50FHSS	Stainless steel flush hinge
Guides	H106/HF/94	Roller guide
	H106SL/94	Spring loaded guide
Channels	H81X	Aluminium channel (1200, 1500, 1800, 2400 & 3600mm lengths)
	H94X	Aluminium (2000, 3000, 4000 & 6000mm lengths)
	H94FM	Aluminium (2000, 3000, 4000 & 6000mm lengths)

Accessories

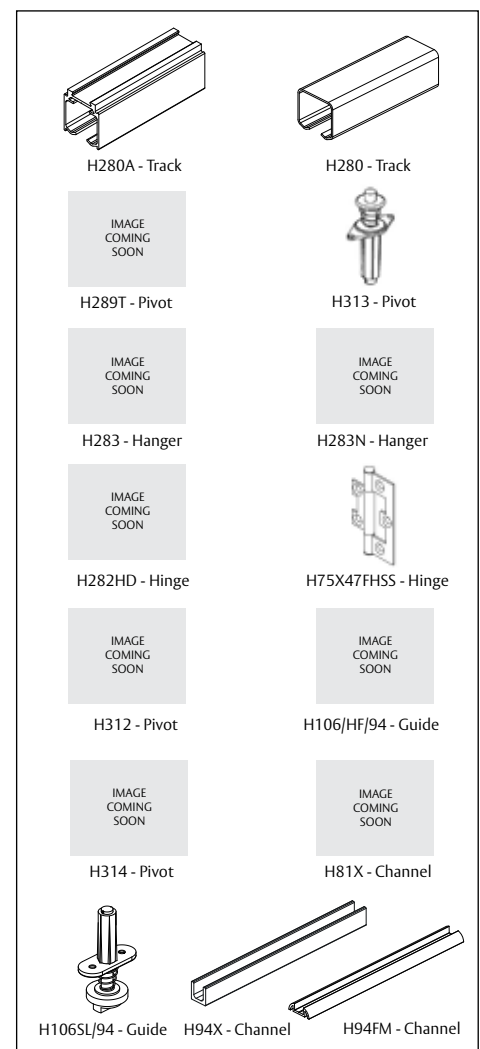
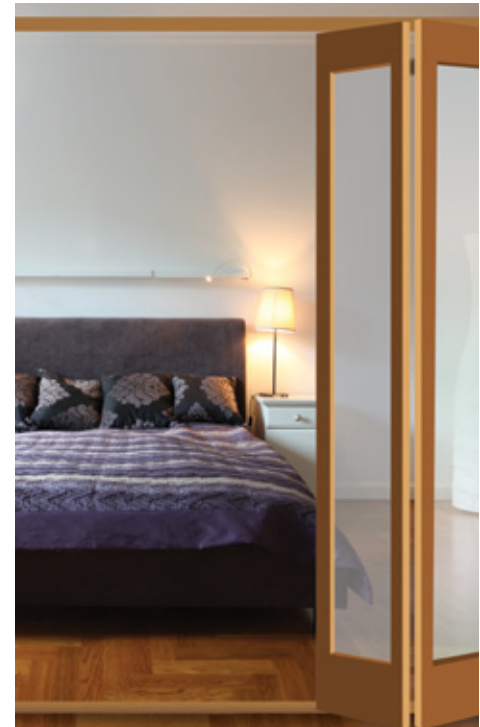

HENDERSON

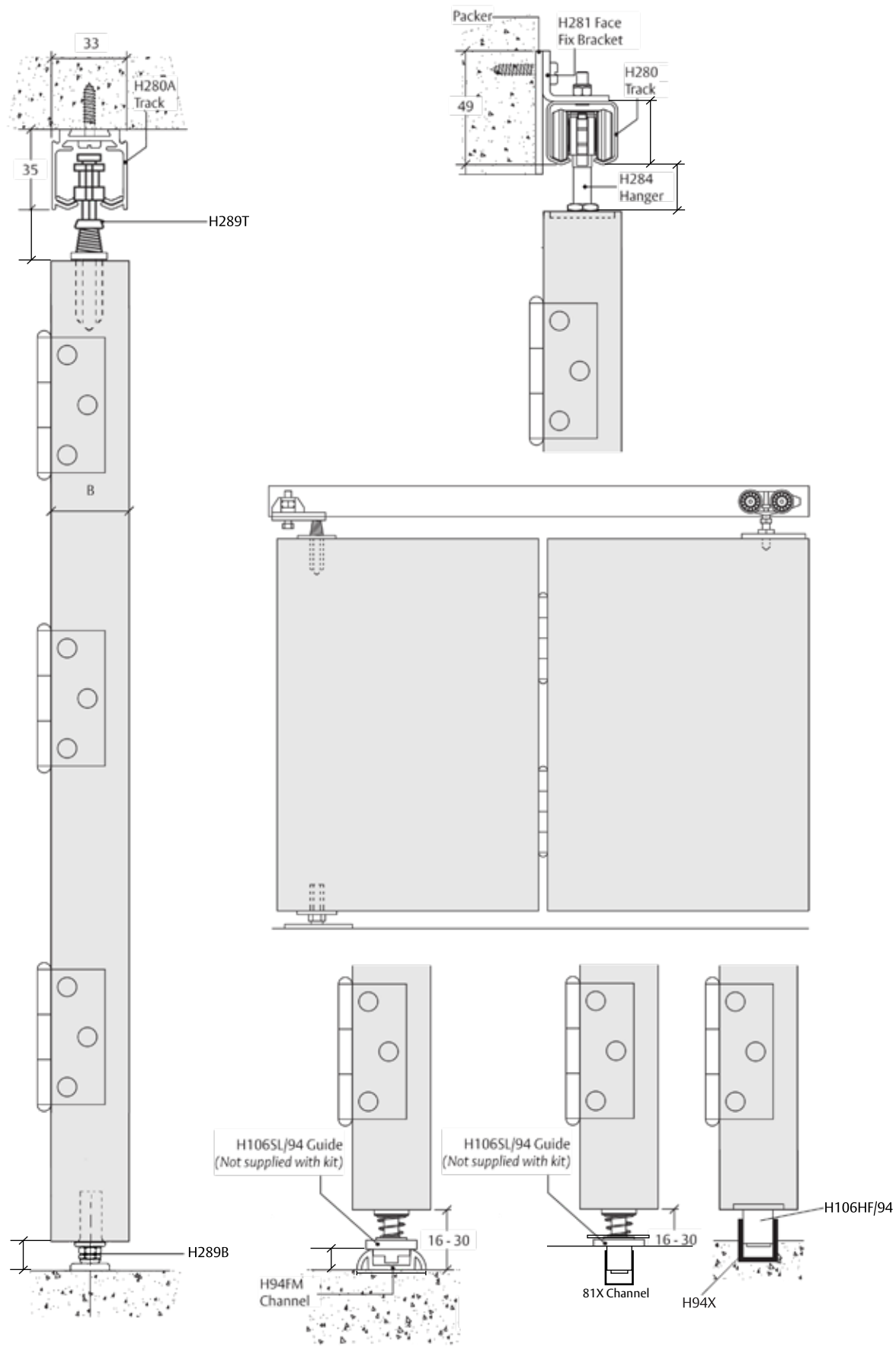

SOLTAIRE PIVOTFOLD

For top hung interior pivot folding partitions. Max 75kg each leaf.

APPLICATION

- Manufactured from high grade 316 stainless steel with anodised aluminium track
- Suitable for residential and commercial pivot folding partition
- The folding unit is not hinged to the jamb, but is pivoted in the track and off the floor
- To cover any width of opening, any number of folding units can be used
- Folding units of up to eight leaves can be pivoted from a post
- Floating units can consist of four, six or eight leaves

DOOR SPECIFICATION

Track System	Soltaire 45	Soltaire 75
For Individual Door Leaves:		
Max Panel Weight	45kg	75kg
Max Panel Width	900mm	900mm
Panel Thickness	35-56mm	35-56mm
Max Panel Height	3000mm	3300mm

HARDWARE SPECIFICATION

Track System	Soltaire 45	Soltaire 75
Track	H180A	H250A
	<i>Anodised aluminium (2000, 3000, 4000 & 6000mm lengths) Soffit fix spacing 900mm centres (maximum)</i>	
Brush Strips	BS10, BS15 , Available in black in 4 brush heights, by the metre BS20, BS25 (mm)	
Brackets	H1/SS	Face fixed stainless steel <i>Starting 20mm from end of track fix at 900mm maximum centres.</i>
Hangers	H21/180/SS H21/250/SS	Timber doors 45kg 4 wheel Timber doors 75kg 4 wheel
Pivots	H21/SS/P H21/SS/PNC	Top and bottom pivot channel fix Top and bottom pivots no channel
Track Stop Hinges	HH5/SS HSF3S HSF5S H100X75LPSS H100X75DHSS	Anodised aluminium with rubber buffer Non-mortice hinge handle set (includes 2 hinges and 1 hinge handle) Non-mortice hinge set (includes 3 hinges) Stainless steel butt hinge Stainless steel D Handle butt hinge
Guides	H21SS/94	Angle plate fixing stainless steel
Channels	H94X H94 H89SS H94P H94PSC	Aluminium (2000, 3000, 4000 & 6000mm lengths) Brass (4000 & 6000mm lengths) Stainless steel (2000 & 3000mm lengths) Polypropylene (2000, 3000, 4000 & 6000mm lengths) Aluminium supporting channel and polypropylene (2000, 3000, 4000 & 6000mm lengths)
Flushbolts	H190S H190LS H450S H450LS H600S H600LS	190mm flushbolt non-locking 190mm flushbolt locking 450mm flushbolt non-locking 450mm flushbolt locking 600mm flushbolt non-locking 600mm flushbolt locking
Flush Pulls		

IMAGE
COMING
SOON

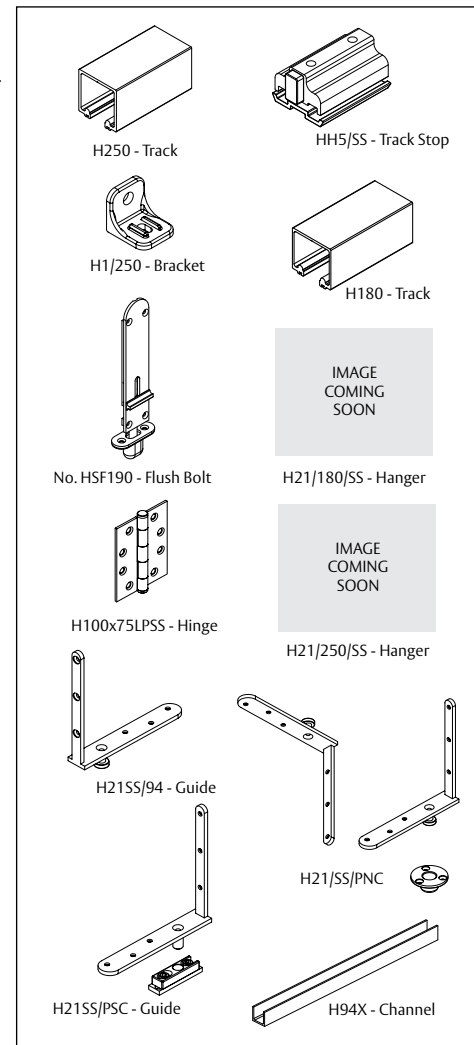

HENDERSON



HENDERSON

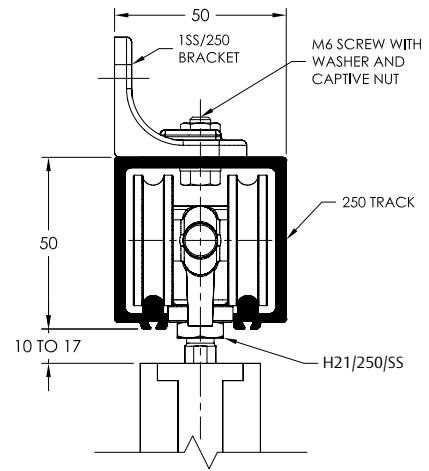
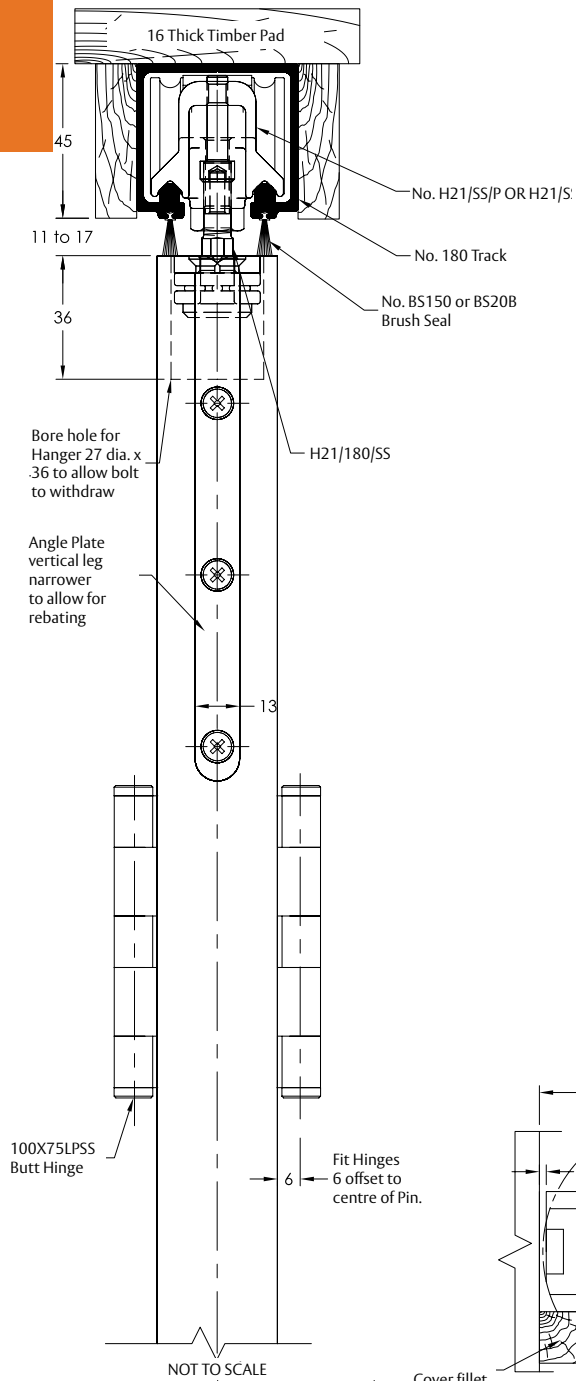

VIEW SHOWING ALTERNATIVE NO. 250 TRACK AND 1/SS BRACKET

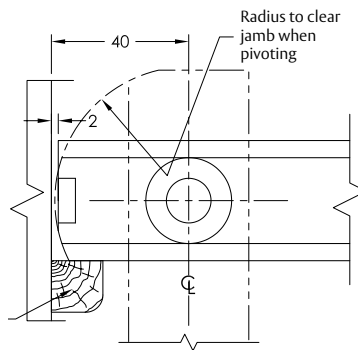
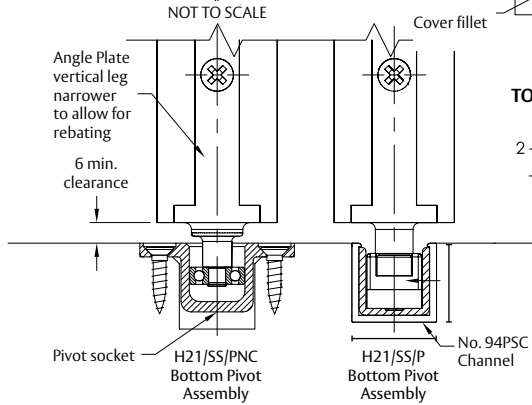

PIVOT DETAIL TOP OF DOOR WITH HANGER REMOVED

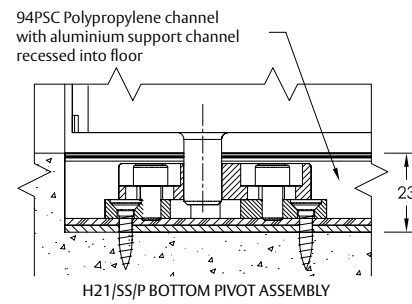
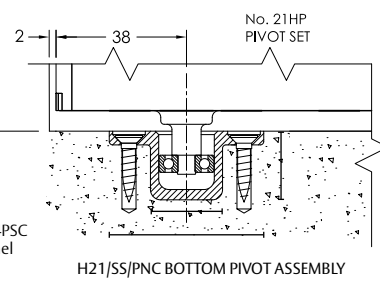

SOLTAIRE ENDFOLD

For top hung interior end folding partitions. Max 75kg each leaf.

APPLICATION

- Manufactured from high grade 316 stainless steel with anodised aluminium track
- Suitable for residential and commercial centre folding partition
- Folding units up to 8 leaves can be hinged to a post
- To cover any width of opening, any number of folding units can be used
- Floating units can consist of four, six or eight leaves

DOOR SPECIFICATION

Track System	Soltaire 45	Soltaire 75
For Individual Door Leaves:		
Max Panel Weight	45kg	75kg
Max Panel Width	900mm	900mm
Panel Thickness	35-56mm	35-56mm
Max Panel Height	3000mm	3300mm

HARDWARE SPECIFICATION

Track System	Soltaire 45	Soltaire 75
Track	H180A	H250A
	<i>Anodised Aluminium (2000, 3000, 4000 & 6000mm lengths)</i> <i>Soffit fix spacing 900mm centres (maximum)</i>	
Brush Strips	BS10, BS15, BS20, BS25 (mm)	Available in black in 4 brush heights, by the metre
Brackets	H1/250	Face fixed stainless steel <i>Starting 20mm from end of track fix at 900mm maximum centres.</i>
Hangers	H21/180/SS H21/250/SS	Timber doors 45kg 4 wheel Timber doors 75kg 4 wheel
Track Stop Hinges	HH5/SS HSF3S HSF5S H100X75LPSS H100X75DHSS	Anodised aluminium with rubber buffer Non-mortice hinge handle set (includes 2 hinges and 1 hinge handle) Non-mortice hinge set (includes 3 hinges) Stainless steel butt hinge Stainless steel D Handle butt hinge
Guides	H21SS/94	Timber doors angle plate to suit 94 channel
Channels	H94X H94 H89SS H94P H94PSC	Aluminium (2000, 3000, 4000 & 6000mm lengths) Brass (4000 & 6000mm lengths) Stainless steel (2000 & 3000mm lengths) Polypropylene (2000, 3000, 4000 & 6000mm lengths) Aluminium supporting channel and polypropylene (2000, 3000, 4000 & 6000mm lengths)
Flushbolts	H190S H190LS H450S H450LS H600S H600LS	190mm flushbolt non-locking 190mm flushbolt locking 450mm flushbolt non-locking 450mm flushbolt locking 600mm flushbolt non-locking 600mm flushbolt locking
Flush Pulls		

IMAGE
COMING
SOON

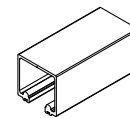

H180 - Track

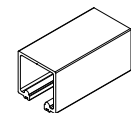

H250 - Track



H1/250 - Bracket

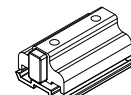

HH5/SS - Track Stop



H21/180/SS - Hanger

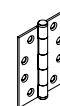

H100X75LPSS - Hinge



HSF190 - Flush Bolt

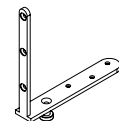

H21SS/94 - Guide

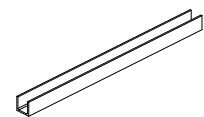

H94X - Channel

HENDERSON

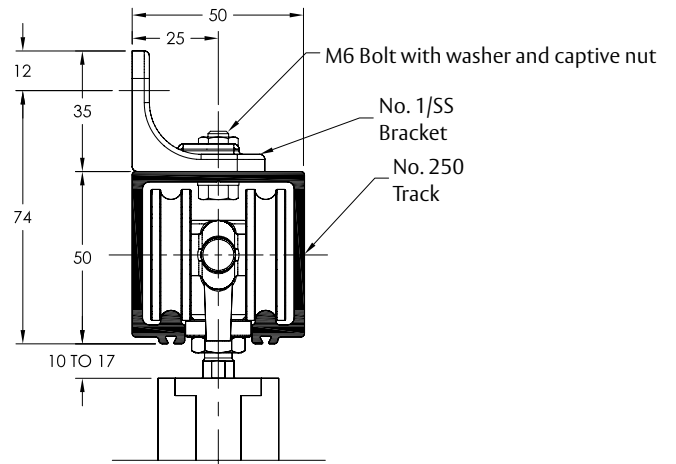
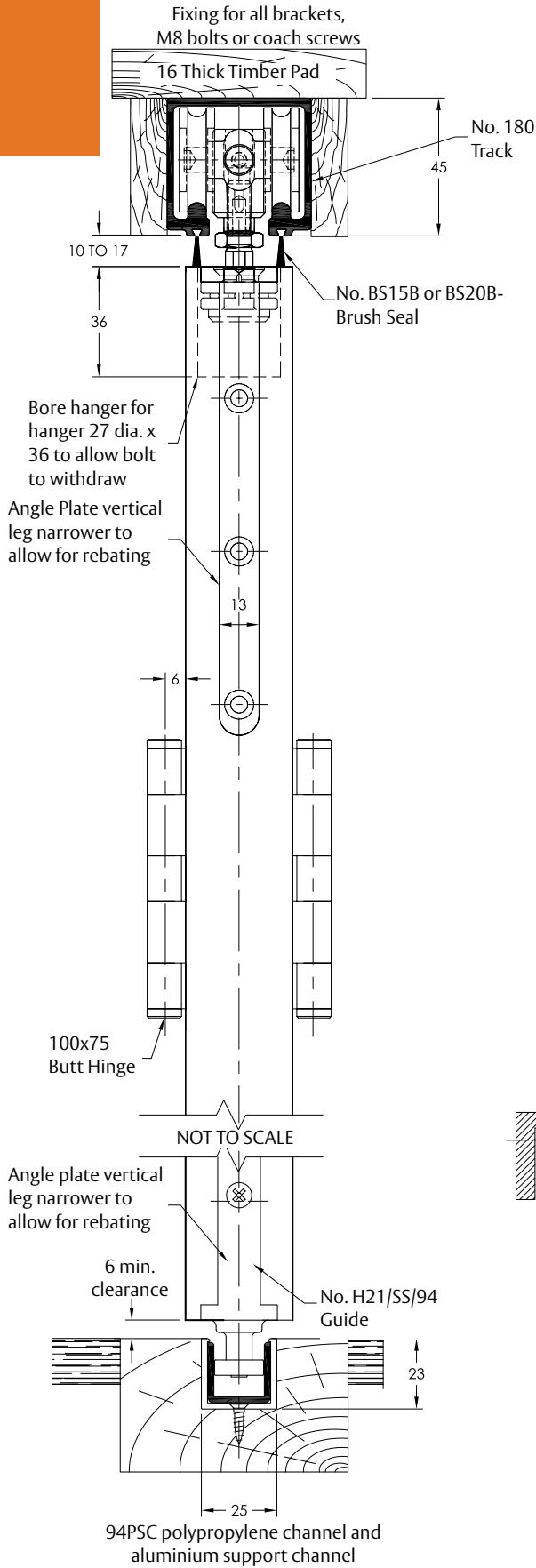

VIEW SHOWING ALTERNATIVE NO. 250 TRACK AND 1/SS BRACKET

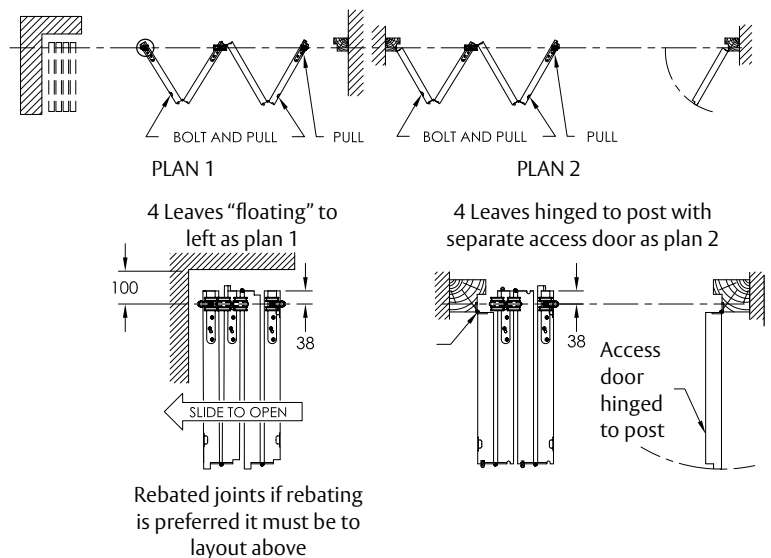

HENDERSON

SOLTAIRE CENTREFOLD

For top hung interior Centre folding doors. 45kg & 75kg each leaf.

APPLICATION

- Manufactured from high grade 316 stainless steel with an anodised aluminium track
- Suitable for residential and commercial centre folding partition
- The leaves are hung centrally under the lintel and can fold to one or both sides
- Folding units of up to 7 full leaves and 1 half leaf can be hinged to a post
- Floating units consists of five, seven or nine full leaves
- To cover any width of opening, any number of folding units can be used

DOOR SPECIFICATION

Track System	Soltaire 45	Soltaire 75
For Individual Door Leaves:		
Max Panel Weight	45kg	75kg
Max Panel Width	900mm	900mm
Panel Thickness	35-56mm	35-56mm
Max Panel Height	3000mm	3300mm

HARDWARE SPECIFICATION

Track System	Soltaire 45	Soltaire 75
Track	H180A	H250A
	<i>Anodised aluminium (2000, 3000, 4000 & 6000mm lengths) Soffit fix spacing 900mm centres (maximum)</i>	
Brush Strips	BS10, BS15 , Available in black in 4 brush heights, by the metre BS20, BS25 (mm)	
Brackets	H1/SS	Face fixed stainless steel <i>Starting 20mm from end of track fix at 900mm maximum centres.</i>
Hangers	H61/180/SS H61/250/SS	Timber doors 45kg Timber doors 75kg
Pivots	H21/SS/P H21/SS/PNC	Top and bottom pivot channel fix Top and bottom pivots no channel
Track Stop	HH5/SS	Anodised aluminium with rubber buffer
Hinges	HSF3S HSF5S H100X75LPSS H100X75D4SS	Non-mortice hinge handle set (includes 2 hinges and 1 hinge handle) Non-mortice hinge set (includes 3 hinges) Stainless steel butt hinge Stainless steel D Handle butt hinge
Guides	H106HSS/94	Concealed fixing stainless steel
Channels	H94X H94 H89SS H94P H94PSC	Aluminium (2000, 3000, 4000 & 6000mm lengths) Brass (4000 & 6000mm lengths) Stainless steel (2000 & 3000mm lengths) Polypropylene (2000, 3000, 4000 & 6000mm lengths) Aluminium supporting channel and polypropylene (2000, 3000, 4000 & 6000mm lengths)
Flushbolts	H190S H190LS H450S H450LS H600S H600LS	190mm flushbolt non-locking 190mm flushbolt locking 450mm flushbolt non-locking 450mm flushbolt locking 600mm flushbolt non-locking 600mm flushbolt locking
Flush Pulls		

IMAGE
COMING
SOON

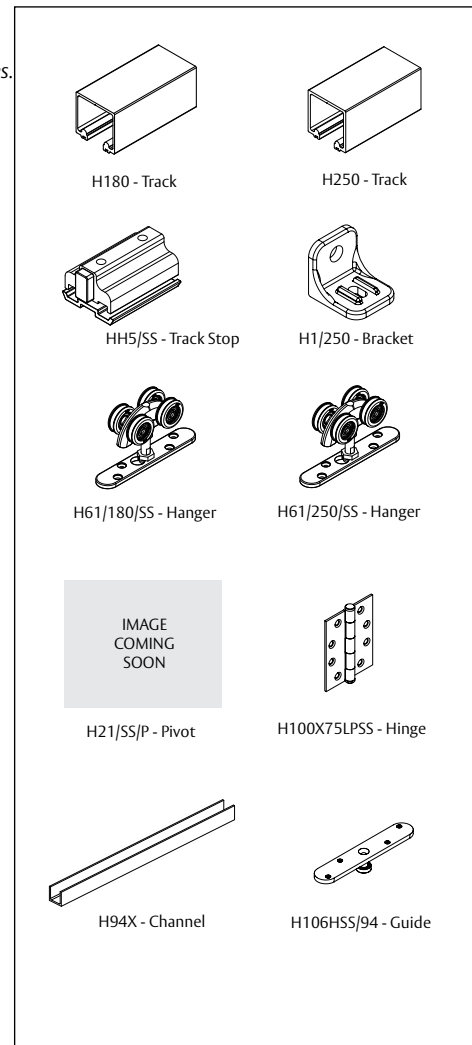

HENDERSON



HENDERSON

