



## Series Model

- SL-180 : Without door position detection output
- SL-180R: With door position detection output

## Special features

- Holding force:300lbs(180Kg).
- Power Supply: DC12V or DC24V (adjustable)
- Fail-safe (power to lock) electric lock suitable for 90° wooden door or chest with drawers.
- Special surface enhancement process which is anti-rust for its durability.
- For use with any types of the access control unit with built-in surge absorber to prevent any interference to the reader.
- Low power consumption with high efficiency, noise-free.

## Specification

	SL-180	SL-180R
Lock status sensor	×	N.C. & N.O. Output (Maximum load of 0.25A)
Power Supply	DC 12V or DC24V ±15%	
Operation current	380mA@12VDC mA ±5% 190mA@24VDC mA ±5%	
Application	90° wooden door or chest with drawers	
Holding forces	300lbs(150Kg)	
Operation temperature	40°C ± 5°C (Room temperature 30°C )	
Weight	1150g (included wrapping)	

## Dimensions

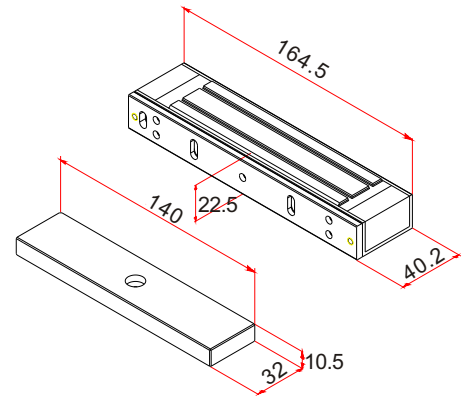

Unit: mm

## Related products

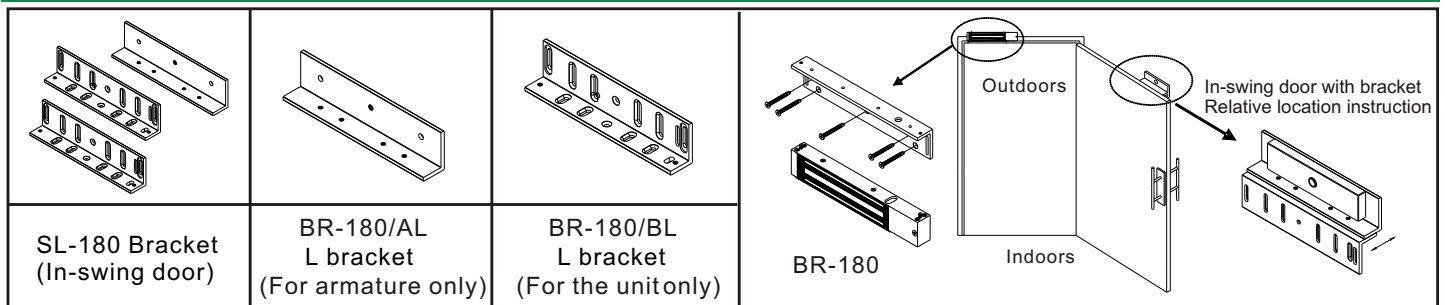

## Structure diagram

