

HES® KS100 Aperio® Wireless Cabinet Lock

ASSA ABLOY

Installation & Operating Instructions

Experience a safer
and more open world

Product Contents

- A** Lock Body
- B** Battery Bracket
- C** Handle Assembly
- D** Cam
- E** SFIC Cam & Spacer
- F** Handing Selectors (L) or (R)
- G** 3x Wire Connector
- H** Screw A: #1/4-20 x 1/2"
Truss Head Phillips
- I** Screw B: #8/32 x 5/16"
Pan Head Phillips
- J** 2X AA Lithium Batteries*

*AA Lithium Batteries required. Use of other types of batteries, such as Alkaline, will significantly decrease battery life.

- K** External DPS Cable Harness
(optional)

NOTE: SFIC mechanical key override/
SFIC blank sold separately

Recommended Tools

- Cutting Wheel
- Phillips #2 Screwdriver

Diagram 1: Product Components

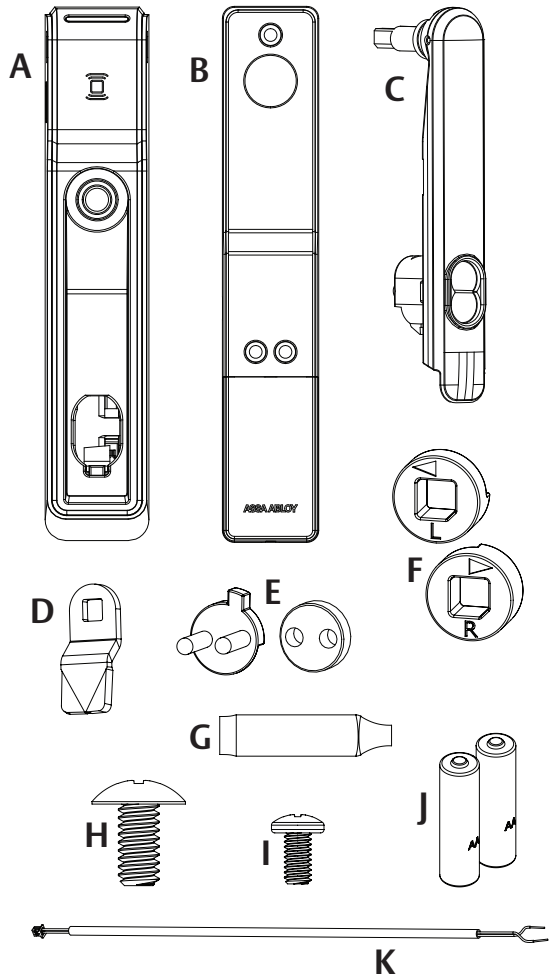

Product Specifications

- **Wireless Frequency**
2.4GHz, IEEE 802.15.4, using AES 128-bit encryption
- **Lock Battery Type** AA Lithium, 1.5 Volts (V)
- **Battery Life** 50,000 cycles*
*All battery life claims are approximate and based on a set configuration profile. Battery performance is based on pre-defined system settings such as battery chemistry and battery model used, credential presentation settings (LED/buzzer), UHF polling period, UHF status intervals, and operations per day. Actual battery performance will vary and depends on the factors above.
- **Holding Force** 400 lbs
- **Operating Temperature**
32° to 122° F (0° to 50° C)

- **HID® multiCLASS SE® technology Credentials Supported:**
 - **High Frequency (13.56 MHz):**
 - » HID iCLASS®
 - » HID iCLASS SE® (SIO-enabled)
 - » HID iCLASS® Seos™
 - » HID MIFARE® SE
 - » HID DESfire® EV1 SE
 - » MIFARE CLASSIC
 - » DESfire® EV1
 - **Low Frequency (125 kHz):**
 - » HID Prox®, AWID, EM4102, ioProx
 - **NFC/BLE***
 - » Mobile – enabled credentials

*Supported on BLE-enabled models

Hardware Specifications

CAM	CAM Length	CAM Depth
38mm – 4 (Standard)	1-1/2" [38mm]	1" [26mm]
38mm – 5 (Optional)	1-1/2" [38mm]	1-1/10" [28mm]
45mm – 1 (Optional)	1-3/4" [45mm]	7/10" [18mm]

Diagram 2: Cam

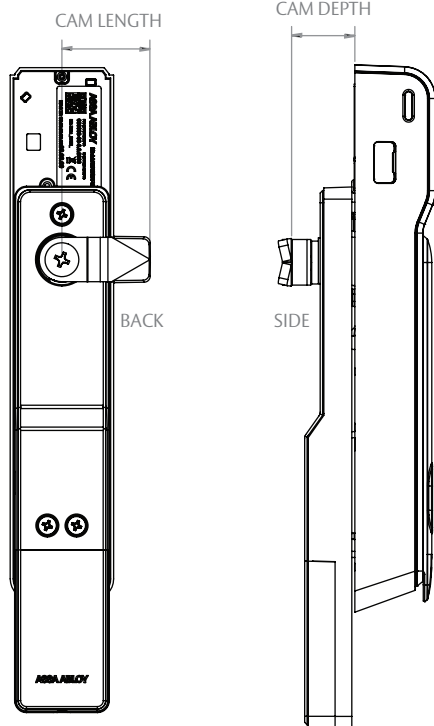

Installing the Lock

1. Locate the 150mm x 25mm lock cutout on the door. Connect battery cable and optional DPS cable to lock body. Secure battery bracket to lockbody using 3x screw B.
2. Ensure lock body is flush against the mounting surface to depress tamper switch.
3. Select appropriate handing selector (Diagram 4).

NOTE: ensure that the arrow on the handing selector is pointing towards the edge of the door.

4. Install handle, handing selector, and cam. Secure with screw A (Diagram 5).

Diagram 3: Install

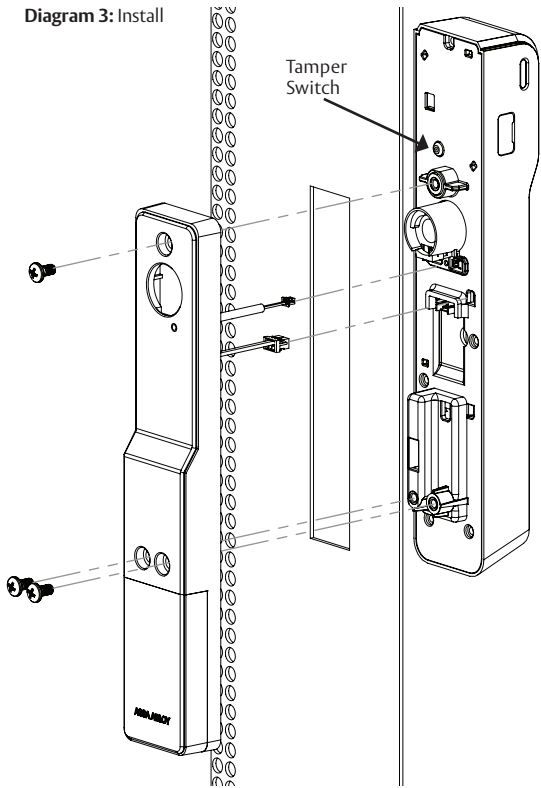

Diagram 4: Handing Selector (R) Shown Below

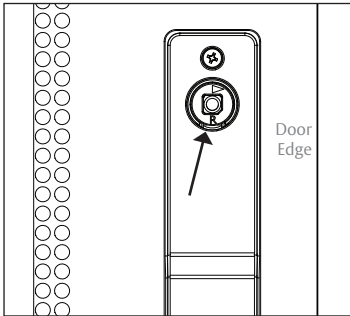
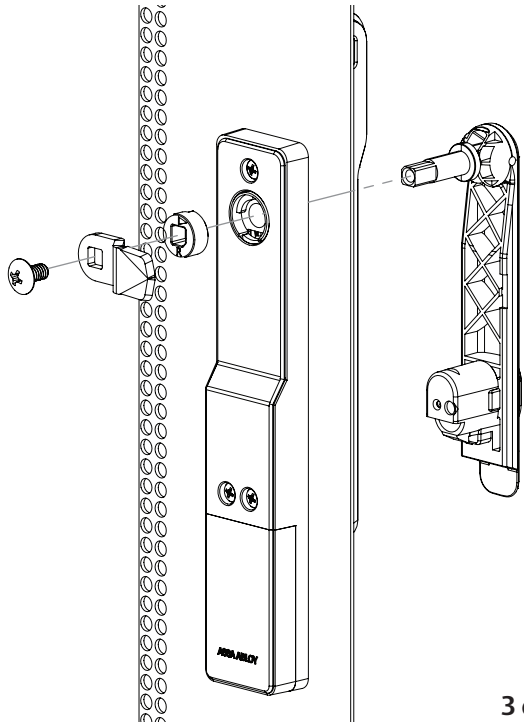

Diagram 5: Cam & Screw A



Installing Batteries

Loosen screw on battery cover, slide cover down, and install batteries in the appropriate orientation.

Diagram 6: Batteries

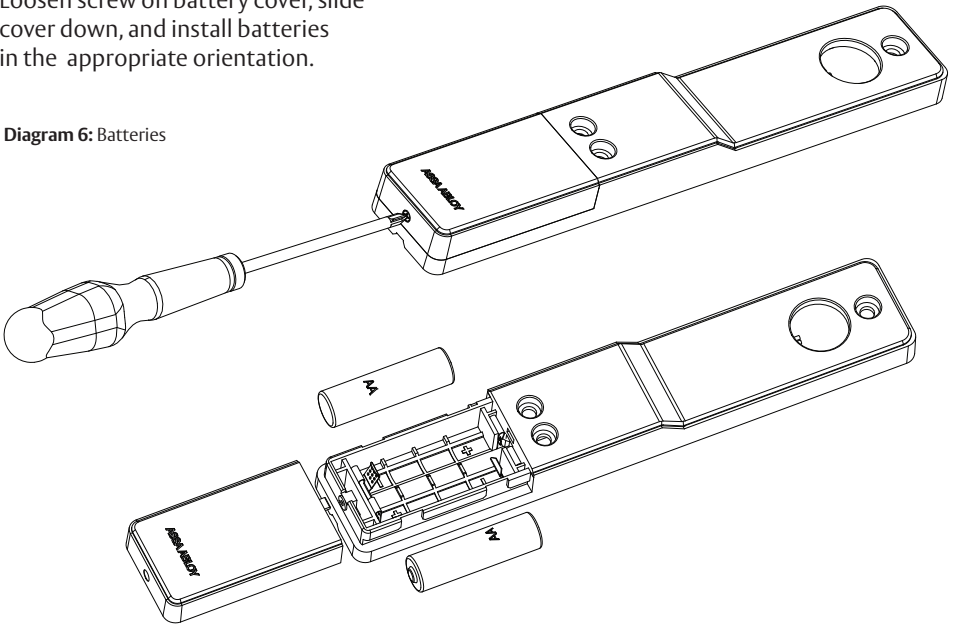
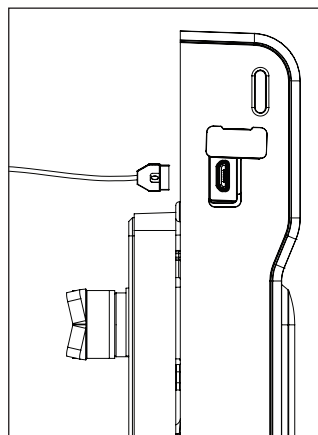

Diagram 7: Micro USB

Micro USB Port

For emergency power & local (hard wired) firmware updates, use micro USB port located on the side of the KS100 reader.



OPTIONAL

DPS Cable Extension

The DPS signal is closed when the handle is resting in its locked position. The DPS circuit can be extended to include normally open DPS switches arranged in a series to monitor additional doors and panels.

Diagram 8: DPS Cable

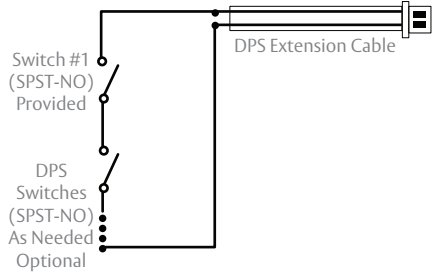

Extending the DPS Circuit:

1. Remove the DPS jumper
2. Connect the included DPS extension cable
3. Connect additional normally open DPS switches as shown to monitor additional panels.

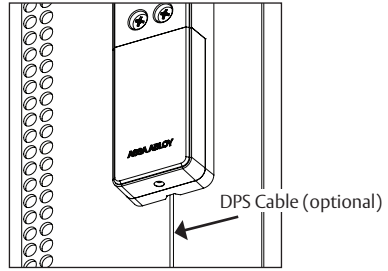

OPTIONAL

Installing the SFIC Core

1. Insert SFIC core and cam into handle. Use spacer for 6 pin SFIC core. Ensure lock body is flush against the mounting surface to depress tamper switch.

NOTE: SFIC blank plastic core (SFIC-BC) sold separately. SFIC Blank is required if no cylinder is used.

Diagram 9: SFIC

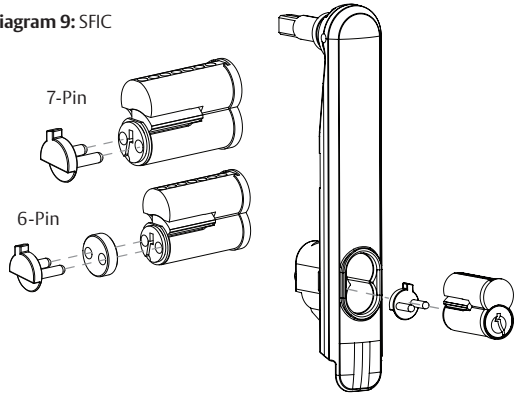











Optional Accessories





Part Number	Description
SFIC	MEDECO X4 7-pin SFIC cylinder & 2 keys (1 Control,1 User)
SFIC-BC	KS SFIC blank, black plastic core
KS-DPS	Surface mount DPS (external)
KS-CAM38	CAM: 38MM - 5 (28mm Depth)
KS-CAM45	CAM: 45MM - 1 (18mm Depth)
AH20W14	ASSA ABLOY Aperio™ AH20 1:1 Wiegand Hub
EXT-10-ANT	ASSA ABLOY Aperio™ Hub External Antenna - 3,9 dBi Omnidirectional
APA-10-PC	ASSA ABLOY Aperio™ Programming Kit
APD-10-USB	ASSA ABLOY Aperio™ USB Radio Dongle

Aperio Hub Specifications

- **Approvals** CE, ETL, FCC, IC, C-Tick
- **Safety & Emissions**
FCC 47CFR Part 15 subpart B and subpart C;
IC RSS-210 EN ETSI 301 489-17 v2.1.1; ENETSI
300 328 v1.7.1; EN 60950-1 ed.2 2007
- **Dimensions** 82mm x 82mm x 37mm
- **Power Supply** 8-24 VDC
- **Current** 250 mA minimum
- **Internal Antenna** 2 cross polarized dipoles
- **External Antenna (Part No. EXT-10-ANT)**
One reverse polarity SMA external antenna
connector. Optional antenna type dipole
with max antenna gain of 3.9dBi
- **Radio Standard** IEEE 802.15.4(2.4GHz)
– 15 channels (11-25)
- **Encryption (Radio Communications)**
AES 128 bits
- **Wireless Operating Range** Up to 50 ft
- **Receiver Sensitivity**
-100dBm 20% PER
- **Wireless Transmit Power** 10 d Bm/MHz
- **Class of Protection** IP 20
- **Operating temperature**
41°F to 95°F [5°C to 35°C]
- **Humidity** < 95% non-condensing
- **Status** LED (red/green/yellow)

LED Codes

Aperio LED LOCK Codes		
(1) ONE Yellow Flash		Card read
(1) ONE Green Flash		Access Granted
(5) FIVE Yellow (1) ONE Red		Force Closed (in open mode)
Continuous Yellow Flashes (.25 sec every second)		Comhub busy
(1) ONE Red Flash		Access Denied (AC Online)
(3) THREE Red Flash		Access Denied (AC Offline)
Continuous Red Flashes (.125 sec every second)		Lock is Blocked (when closing)
(10) TEN Red Flashes		Error in Lock
Continuous Yellow Flashes (.25 sec every 5 seconds)		Low Battery
Continuous Red Flashes (.25 sec every 5 seconds)		Dead Battery

Aperio LED HUB Codes		
Steady Green		Online
Steady Green + (1) ONE Red Flash		Lock Offline
Steady Green + (2) TWO Red Flashes		Access Control Offline
Steady Green + (3) Three Red Flashes		Access Control & Lock Offline
Flashing Yellow		UHF Communication

Connecting the Hub

The following applies only to Aperio factory paired kits with AH20 Hubs.

1. Connect the Wiegand D1, D0, red, and green LED signals.

NOTE: The Green LED input is used to grant access to the cabinet lock. If the Green LED signal is not available to indicate approved access, the approval input can be activated by a relay with "NO" attached to Green LED and "C" to GND. The Red LED input is used to indicate access denied. If the RED LED signal is not connected, the lock will flash RED three times when a non-approved card is presented indicating loss of connection to the hub rather than access denied. Any other codes may be reference on the LED reference card.

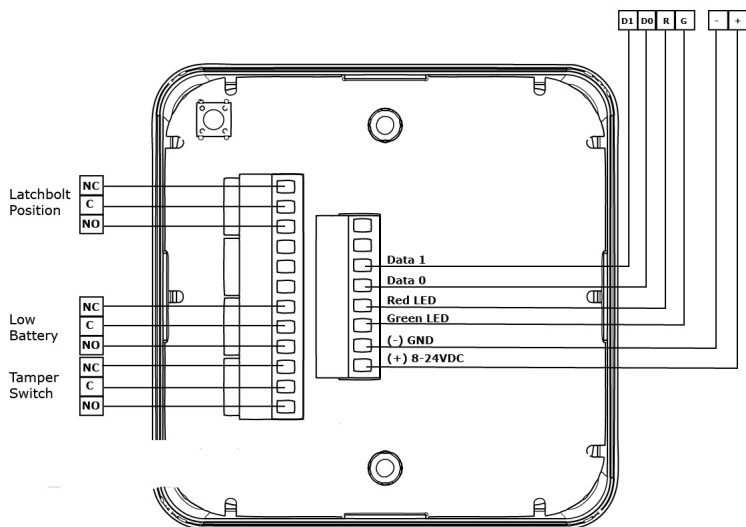

For placement of hub, see AH20/AH30
Installation Instructions

WARNING

FCC Statement

This equipment has been tested and found to comply with the limits for a class B digital device, pursuant to part 15 of the FCC Rules. These limits are designed to provide reasonable protection against harmful interference in a residential installation. This equipment generates, uses, and can radiate radio frequency energy and if not installed and used in accordance with the instructions, may cause harmful interference to radio communications. However, there is no guarantee that interference will not occur in a particular installation. If this equipment does cause harmful interference to radio or television reception, which can be determined by turning the equipment off and on, the user is encouraged to try to correct the interference by one or more of the following measures:

1. Reorient or relocate the receiving antenna.
2. Increase the separation between the equipment and receiver.
3. Connect the equipment into an outlet on a circuit different from that to which the receiver is connected.
4. Consult the dealer or an experienced radio/TV technician for help.

Operation with non-approved equipment is likely to result in interference to radio and TV reception. The user is cautioned that changes and modifications made to the equipment without the approval of manufacturer could void the user's authority to operate this equipment. To comply with FCC and Industry Canada RF radiation exposure limits for general population, the module must be installed to provide a separation distance of at least 20cm from all persons and must not be collocated or operating in conjunction with any other antenna or transmitter.

This module is labeled with its own FCC ID and IC Certification Number. If the FCC ID and IC Certification Number are not visible when the module is installed inside another device, then the outside of the device into which the module is installed must also display a label referring to the enclosed module. In that case, the final end product must be labeled in a visible area with the following:

Contains FCC ID: VC3-R100V3

Contains IC: 7160A-R100V3

IC Statement

This device complies with Industry Canada license-exempt RSS standards(s). Operation is subject to the following two conditions:

- (1) this device may not cause interference, and
- (2) this device must accept any interference, including interference that may cause undesired operation.

Conformité aux normes FCC

Cet équipement a été testé et trouvé conforme aux limites pour un dispositif numérique de classe B, conformément à la Partie 15 des règlements de la FCC. Ces limites sont conçues pour fournir une protection raisonnable contre les interférences nuisibles dans une installation résidentielle. Cet équipement génère, utilise et peut émettre des fréquences radio et, s'il n'est pas installé et utilisé conformément ment aux instructions du fabricant, peut causer des interférences nuisibles aux communications radio. Rien ne garantit cependant que l'interférence ne se produira pas dans une installation particulière. Si cet équipement provoque des interférences nuisibles à la réception radio ou de télévision, qui peut être déterminé en comparant et en l'éteignant, l'utilisateur est encouragé à essayer de corriger les interférences par une ou plusieurs des mesures suivantes:

1. Réorienter ou déplacer l'antenne de réception.
2. Augmenter la distance entre l'équipement et le récepteur.
3. Branchez l'appareil dans une prise sur un circuit différent de celui auquel le récepteur est connecté.
4. Consultez votre revendeur ou un technicien radio / TV pour assistance. Avertissement

Les changements ou modifications à cet appareil sans expressément approuvée par la partie responsable de conformité pourraient annuler l'autorité de l'utilisateur de faire fonctionner cet équipement. L'opération est soumise aux deux conditions suivantes:

- (1) Cet appareil ne doit pas causer d'interférences nuisibles, et
- (2) Cet appareil doit accepter toute interférence reçue, y compris les interférences susceptibles de provoquer un fonctionnement indésirable.

Pour se conformer aux limites d'exposition aux rayonnements RF de la FCC et d'Industrie Canada pour la population en général, le module doit être installé pour fournir une distance de séparation d'au moins 20 cm de toutes les personnes et ne doit pas être localisé ou en combinaison avec une autre antenne ou émetteur.

Ce module est étiqueté avec son ID FCC et son numéro de certification IC. Si l'identifiant FCC et le numéro de certification IC ne sont pas visibles lorsque le module est installé à l'intérieur d'un autre appareil, l'extérieur de l'appareil dans lequel le module est installé doit également afficher une étiquette faisant référence au module ci-joint. Dans ce cas, le produit final doit être étiqueté dans une zone visible avec ce qui suit:

Contient FCC ID: VC3-R100V3

Contient IC ID:7160A-R100V3

Conformité aux normes IC

Cet appareil est conforme avec Industrie Canada exempt de licence RSS standard(s). Son fonctionnement est soumis aux deux conditions suivantes:

- (1) cet appareil ne peut causer d'interférences, et
- (2) cet appareil doit accepter toute interférence, y compris des interférences qui peuvent provoquer un fonctionnement indésirable du périphérique.

8 of 8

ELECTRONIC SECURITY HARDWARE

HES | Securitron

techsupport.esh@assaabloy.com | 800 626 7590

assaabloyesh.com

10027 S. 51st Street, Ste. 102 Phoenix, AZ 85044 USA

Patent pending and/or patent www.assaabloydss.com/patents

Copyright © 2020, Hanchett Entry Systems, Inc., an ASSA ABLOY Group company. All rights reserved. Reproduction in whole or in part without the express written permission of Hanchett Entry Systems, Inc. is prohibited. 3080006.017_4